

Änderungen vorbehalten
Modifications reserved
Modifications réservées
Salvo modificaciones

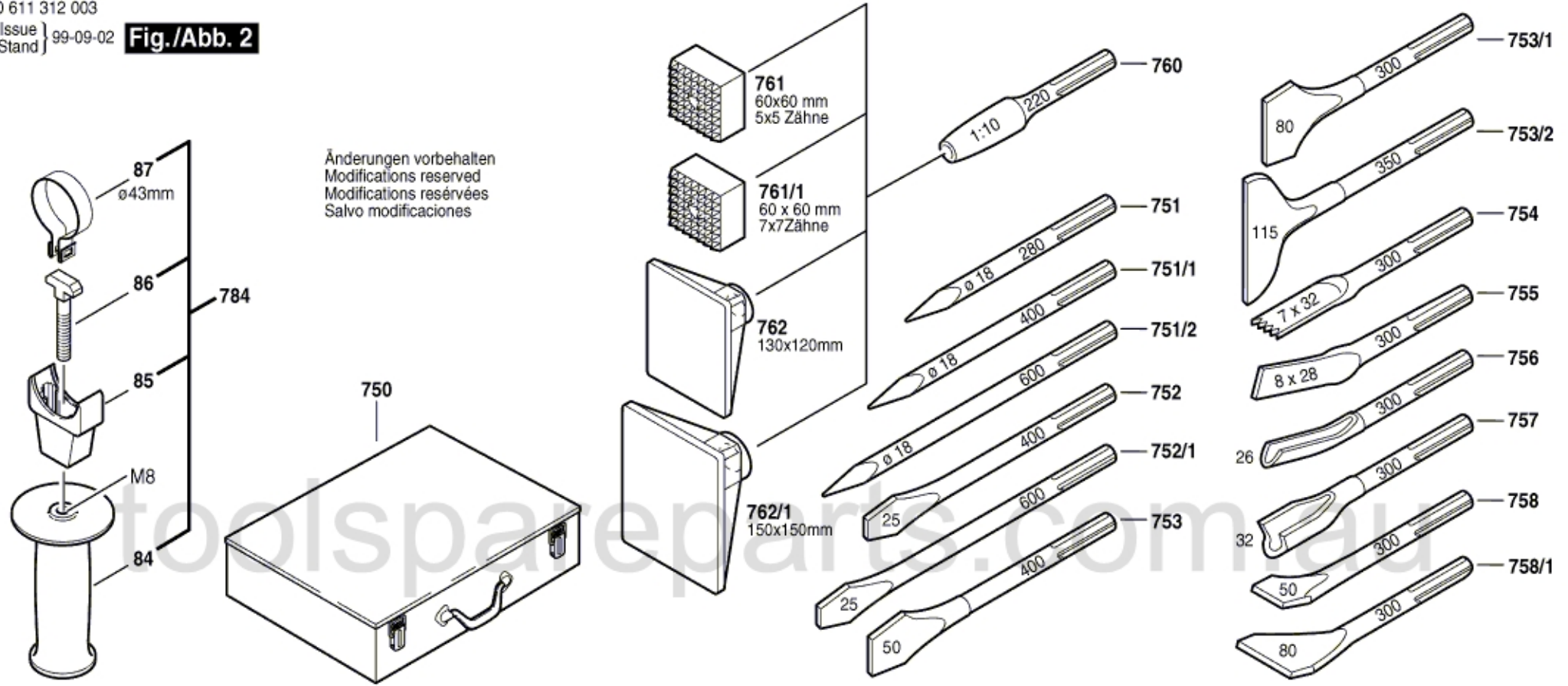

Vor Ankerdemontage- und Montage beide Bürstenhalter 5-7 mm nach außen ziehen.
For armature disassembly and assembly pull the brush holder 5-7 mm outwards.

Nach der Ankermontage Bürstenhalter nach innen drücken und festschrauben.
After armature assembly, press in the brush holder and tighten the screw.

Kohlebürsten mit Flachstecker einsetzen.
Fit brushes and electrical contact.

Litzen beider Kohlebürsten um 180° drehen.
Turn both the Brush wires 180° as shown.

Abstand herstellen (min. 1mm) zwischen Flachstecker und Kohlebürstenhalter.
Abdeckkappen Pos. 47 bis Anschlag aufschieben.
In order to fit pos. 47 there must be at least 1 mm distance between the brush holder and the electrical contact. Press pos. 47 firmly into position.

